

# Viking 4G Electric Static Jacketed Kettle

## Viking 4G 150E (4224108)

**Standard Features**

- 150 litre capacity
- Electric heated version
- Elevated control pillar with selected features
- Electromechanical controls
- Stepless temperature control
- Electric tilting – tilting height 600mm
- Auto tilt-back
- Measuring stick
- Retractable handshower
- Strainer plate
- Stainless steel construction
- Unit shown includes free standing floor kit - other options available

*Please refer to Moffat price list for options and accessories*

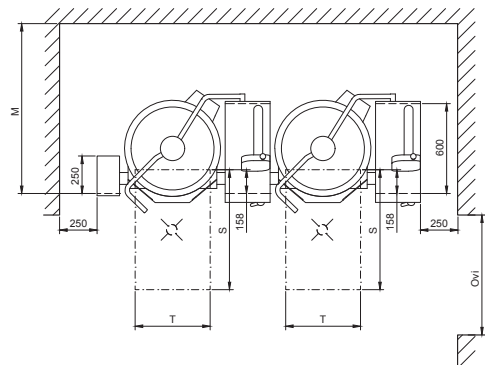
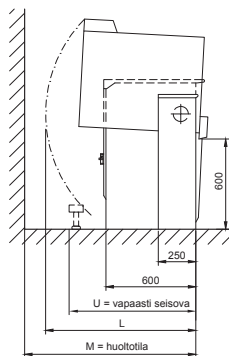
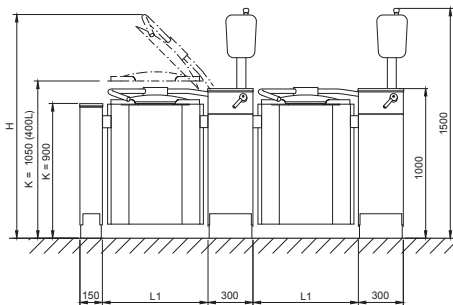

**Technical Data**

Net Volume 150 L  
Spare Volume 19 L  
Gross Volume 169 L

**Dimensions**

Width 1360mm  
Height 1500mm  
Depth 880mm

**Connections**

Water Cold ø15mm  
Hot ø10mm

**Electrical**  
Power 20 kW  
Voltage 400-415V,  
3P+N+E 50/60Hz  
AMP 32A

**Total Heat**  
Load 20 kW  
Latent 1.0 kW,  
Sensible 4.3 kW

**Waste**  
By kitchen contractor  
**Nett Weight** 250 kg

Model	L1 mm	H mm	L mm	M mm	U mm	T mm	Door mm
150E	910	1945	1075	1170	1110	600	1000

**Australia**  
[moffat.com.au](http://moffat.com.au)  
**Moffat Pty Limited**  
740 Springvale Road  
Mulgrave  
Victoria 3170  
Australia  
Telephone +613-9518 3888  
Facsimile +613-9518 3833  
[vsales@moffat.com.au](mailto:vsales@moffat.com.au)

**New Zealand**  
[moffat.co.nz](http://moffat.co.nz)  
**Moffat Limited**  
45 Illinois Drive  
Izone Business Hub  
Rolleston 7675  
New Zealand  
Telephone +64 3-983 6600  
Facsimile +64 3-983 6660  
[sales@moffat.co.nz](mailto:sales@moffat.co.nz)



Disclaimer: All unit capacities are based on subjective testing. Moffat accepts no liability for production values. In line with policy to continually develop and improve its products, Moffat Limited reserves the right to change specifications and design without notice.

© Copyright Moffat Ltd  
AN-MET-S-2001