



INSTRUCTION MANUAL

For **Solid Top Chest Freezer**

BD-65

BD-105

BD-155

BD-205

BD-255

BD-350

BD-450

BD-550

BD-650

BD-450SS

BD-550SS

BD-650SS



Please read this user's manual thoroughly before using.

Keep this manual handy for further reference.

Warranty Information

One YEAR WARRANTY

All claims for parts or labor must be made directly through Atosa. All claims must include: model number of the unit, the serial number, proof of purchase, date of installation, and all pertinent information supporting the alleged defect. In case of compressor replacement under warranty, either compressor or compressor tag must be returned to Atosa along with above listed information. **Failure to comply with warranty policies will result in voiding claims.**

One Year Parts & Labor Warranty

Atosa warrants all new refrigerated components, such as the cabinet and all parts, to be free from defects in materials or workmanship. Atosa's obligation under this warranty is limited to a period of one (1) years from the date of original installation or 15 months after shipment date from Atosa, whichever occurs first. All parts covered under this warranty that are defective within one (1) years of original installation or fifteen (15) months after shipment date from manufacturer, whichever occurs first, are limited to repair or replacement (including labor charges, of defective parts or assemblies) The labor warranty shall include standard straight time labor charges only and reasonable travel time, as determined by Atosa.

Additional Four Year Compressor Warranty

In addition to the one (1) Year warranty stated above, Atosa warrants its sealed compressor to be free from defects in both material and workmanship under normal and proper use and maintenance service for a period of four (4) additional years from the date of original installation, but not to exceed five (5) years. Compressors that have been determined to be defective from Atosa within this extended period will be either repaired or replaced with a compressor or compressor parts of similar design and capacity according to Atosa's discretion. The four (4) year extended compressor warranty applies only to sealed parts of the compressor and does not apply to any other parts or components. This includes, the cabinet, paint finish, temperature control, refrigerant, metering device, motor starting equipment, fan assembly and other electrical components, etc.

Compressor Warranty

The five-year compressor warranty detailed above will be void if the following procedure is not carefully adhered to:

1. This system contains refrigerant and lubricant. The lubricant has rapid moisture absorbing qualities.
2. Drier replacement is very important and must be changed when a system is opened for servicing.
3. Micron level vacuums must be achieved to insure low moisture levels in the System.
4. Compressor must be obtained through Atosa unless otherwise specified in writing through Atosa's warranty department.

What is Not Covered by This Warranty

Atosa's sole obligation under this warranty is limited to either repair or replacement of parts, subject to the additional limitations below. This warranty neither assumes nor authorizes any person to assume obligations other than those expressly covered by this warranty.

NO CONSEQUENTIAL DAMAGES: ATOSA IS NOT RESPONSIBLE FOR ECONOMIC LOSS; PROFIT LOSS; OR SPECIAL, IN DIRECT, OR CONSEQUENTIAL DAMAGES, INCLUDING WITHOUT LIMITATION, LOSSES, OR DAMAGES ARISING FROM FOOD OR PRODUCT SPOILAGE, REGARDLESS OF WHETHER OR NOT THEY RESULT FROM REFRIGERATION FAILURE.

WARRANTY IS NOT TRANSFERABLE: This warranty is not assignable and applies only in favor of the original purchase /user to whom delivered. ANY SUCH ASSIGNMENT OR TRANSFER SHALL VOID THE WARRANTIES HEREIN AND SHALL VOID ALL WARRANTIES, EXPRESS OR IMPLIED, INCLUDING ANY WARRANTY OF MERCHANTABILITY OR LABOR COVERAGE FOR COMPONENT FAILURE OR OTHER THE WARRANTY PACKET PROVIDED WITH THE UNIT.

ALTERATION.NEGLECT.ABUSE. MISUSE, ACCIDENT, DAMAGE DURING TRANSIT OR INSTALLATION, FIRE, FOOD, OR ACTS OF GOD:

Atosa is not responsible for the repair or replacement of any parts that are determined to have been subjected after the date of manufacture to alteration, neglect, abuse, misuse, accident, damage during transit or installation, fire, flood, or act of God.

IMPROPER ELECTRICAL CONNECTIONS:Atosa IS NOT RESPONSIBLE FOR THE REPAIR OR REPLACEMENT OF FAILED OR DAMAGED COMPONENTS RESULTING FROM ELECTRICAL POWER FAILURE, THE USE OF EXTENSION CORDS, LOW VOLTAGE, OR VOLTAGE DROPS TO THE UNIT.

THE ONE(1) YEAR PARTS & LABOR WARRANTYAND THE ADDITIONAL FOUR (4) YEAR COMPRESSOR WARRANTY ARE AS DESCRIBED ABOVE. THESE WARRANTIES ARE EXCLUSIVE AND IN LIEU OF ALL OTHER WARRANTIES, INCLUDING IMPLIED WARRANTY AND MERCHANTABILITY OR FITNESS FOR A PARTICULARPURPOSE. THERE ARE NO WARRANTIES WHICH EXTEND BEYOND THE DESCRIPTION ON THE FACE HEREOF.

Outside U.S. and Canada:This warranty does nor apply to areas outside the continent of the United States. Atosa is not responsible for any warranty claims made on products sold or used in such areas.

In some cases, a 25 % restocking fee may be charged to a buyer for returned items.

Atosa may at any time modify our equipment in order to provide and insure a superior product. Change is sometimes necessary to keep up with today's high standards in our industry. Atosa reserves the final interpretation of all public material.



Important Child Safety

Destroy or recycle the carton, plastic bags, and any exterior wrapping material immediately after the unit is unpacked. Children should **never** use these items to play.

Product Information

--Preface

This instruction manual provides all the necessary information regarding:

- Use of the freezer
- Technical specifications
- Installation and handling
- Operator procedures and instructions
- Maintenance operation

The manual is to be considered an integral part of the freezer and should be stored in a safe place for future references to insure a long life of the freezer.



ATTENTION

The manufacturer cannot be held liable in the following cases:

- Improper installation(not in accordance with the guidelines indicated herein)
- Misuse of the freezer
- Power supply defects
- Improper or inadequate maintenance
- Unauthorized modification or tampering
- Use of non-original spare parts
- Partial or total failure to comply with the instructions

All electrical equipment can be hazardous to health. Current standards and legal requirements must be complied with during the installation and use of any equipment.

--Use of this equipment

The freezers are for preserving packaged foods (foods that are bottled, canned, cartoned, securely bagged, or securely wrapped in a container).

The operating temperature for frozen food maintenance is:

- Between -8°F and -1°F at room temperature of 109°F and 60% RD.

--Technical Specification

| Model | Rated Electric | Rated Frequency (Hz) | Refrigrant/ Charging(g) | Net Capacity(L) | Temperature (°C) | Net weight (KG) |
|---------------|----------------|----------------------|-------------------------|-----------------|-------------------|-----------------|
| BD-65 | 220~240V | 50 | R600a /40 | 60 | ≤18 | 28 |
| BD-105 | 220~240V | 50 | R600a /50 | 97 | ≤18 | 30.5 |
| BD-155 | 220~240V | 50 | R600a /54 | 148 | ≤18 | 38.5 |
| BD-205 | 220~240V | 50 | R600a /65 | 197 | ≤18 | 40 |
| BD-255 | 220~240V | 50 | R600a /72 | 247 | ≤18 | 43.5 |
| BD-350 | 220~240V | 50 | R600a /78 | 272 | ≤18 | 52 |
| BD-450/ 450SS | 220~240V | 50 | R600a /86 | 358 | ≤18 | 60 |
| BD-550/ 550SS | 220~240V | 50 | R600a /95 | 450 | ≤18 | 75 |
| BD-650/ 650SS | 220~240V | 50 | R600a /100 | 550 | ≤18 | 82 |

Installation Instruction

--Unpacking and Handling

The freezer is in the package of cardboard box with foam boards protect when it arrives at user's place. The freezer must be transported and handled with care to avoid posing a hazard to persons or property. Never place a freezer on its side or turn it upside down as this may damage or impair operation of the refrigerated unit.

We can notheld liable for any damage or defects arising directly or indirectly from improper handling of the equipment or non-compliance with the safeguards illustrated above.

-- Side clearance for the freezer

Install the freezer in an indoor and well-ventilated area with even flat ground.

Keep side clearance for the freezer, leave a 3 inch (75mm) clearance at each side of the freezer for adequate air circulation.

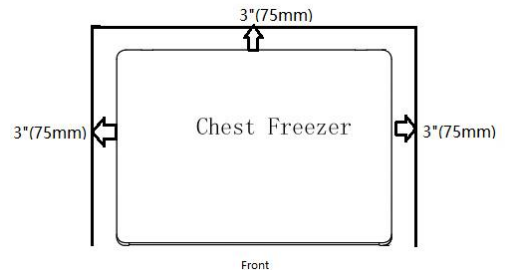

--Electric connection



WARNING

Electric connection must be carried out by professional and qualified persons

The mains voltage corresponds to the voltage on the freezer 220-240VAC; to ensure proper operation it is essential for the power supply voltage to come within a range of +/-10% of the unit's rated voltage.

The freezer should be plugged into a grounded and properly-sized electrical outlet with appropriate overcurrent protection. Please refer to the electrical requirements on the nameplate.

Make sure that your unit has its own dedicated outlet. Do not use an extension cord.

Do not cut, remove or bypass the grounding prong

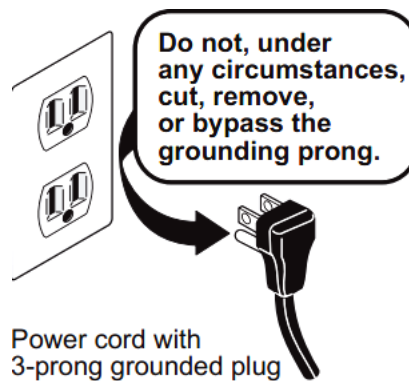
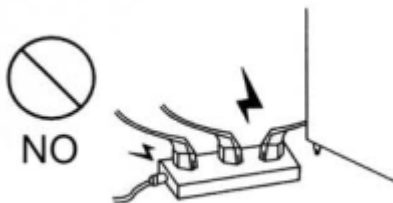

--Door handle Installation

ALL the model have extension door handle, it need to be installed at field when the freezer is located in the user place, the door handle parts are packed in a bag inside cabinet when freezer arrive at user location.

The procedure of handle installation is:

- Install the handle frame at the front edge of door according to existing screw hole located at door;
- Install door lock latch on the cabinet according to screw holes located at front of cabinet;
- Install the handle cover on the handle frame.

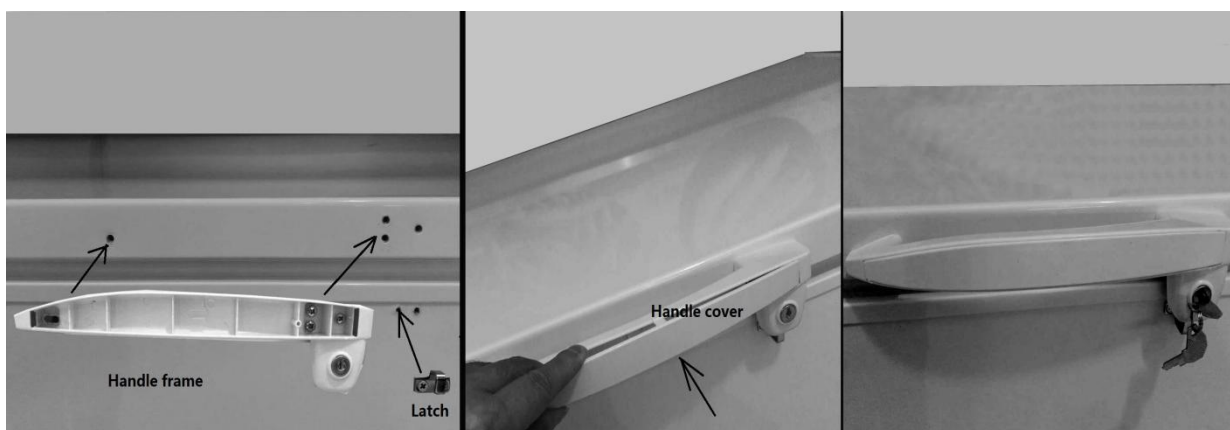

Operation Instruction

--Setting temperature control

For safe food storage, let the freezer run for 4 hours continuously, before placing food into the cabinet.

The temperature setting of the freezer can be adjusted by moving the thermostat axis position. It can be changed with screw driver or a coin shaped tool. The recommended setting for the freezer is at position “4”. Turn axis to its original position when the articles are frozen. Do not fast freeze for more than 4-5 hours. To decrease the temperature (colder), turn towards position close “7”. To increase the temperature (warmer), turn towards position close “1”.



CAUTION

Setting the temperature control to the coldest setting may cause the evaporator coil to freeze and ice up. This will eventually result in a warmer cabinet temperature.

Maintenance Instruction

--Care and Cleaning

The freezer should be cleaned periodically; generally clean it every 30-45 days. Unplug before cleaning and use a soft cloth with a solution of warm water and mild soap to scrub inside and outside of the cabinet.

Do not use acids, chemical thinner, gasoline or benzene for cleaning any part of the chest freezer. Dry it with a soft cloth. Never use water to rinse the freezer.

--Defrost

If the frost on the interior walls is more than 1/4", defrosting should be done.

Method of defrosting:

- 1) Unplug the unit. Remove all contents of the freezer. After the freezer temperature rises, frost will melt or scale off.
- 2) To speed up defrosting, place a pan of hot water into the unit and close the door. After defrosting, drain the water through the drain hole at bottom of cabinet, and then use a soft cloth to dry the interior walls. Plug unit in and resume operation. Wait until unit reaches desired temperature before returning product to the freezer.

Remember replace the drain plugs when defrosting and cleaning are completed. If the drain is left open, warm air may enter the freezer.

Note: Never use sharp utensils or ice scrapers to scrape off frost.

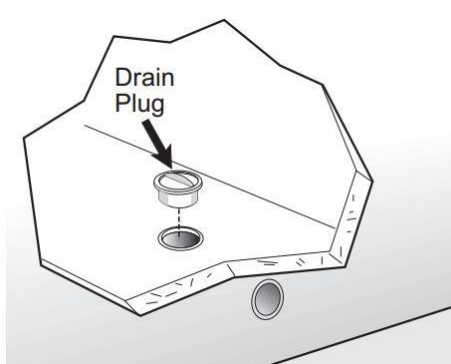

Technical Service Information

--Explore view

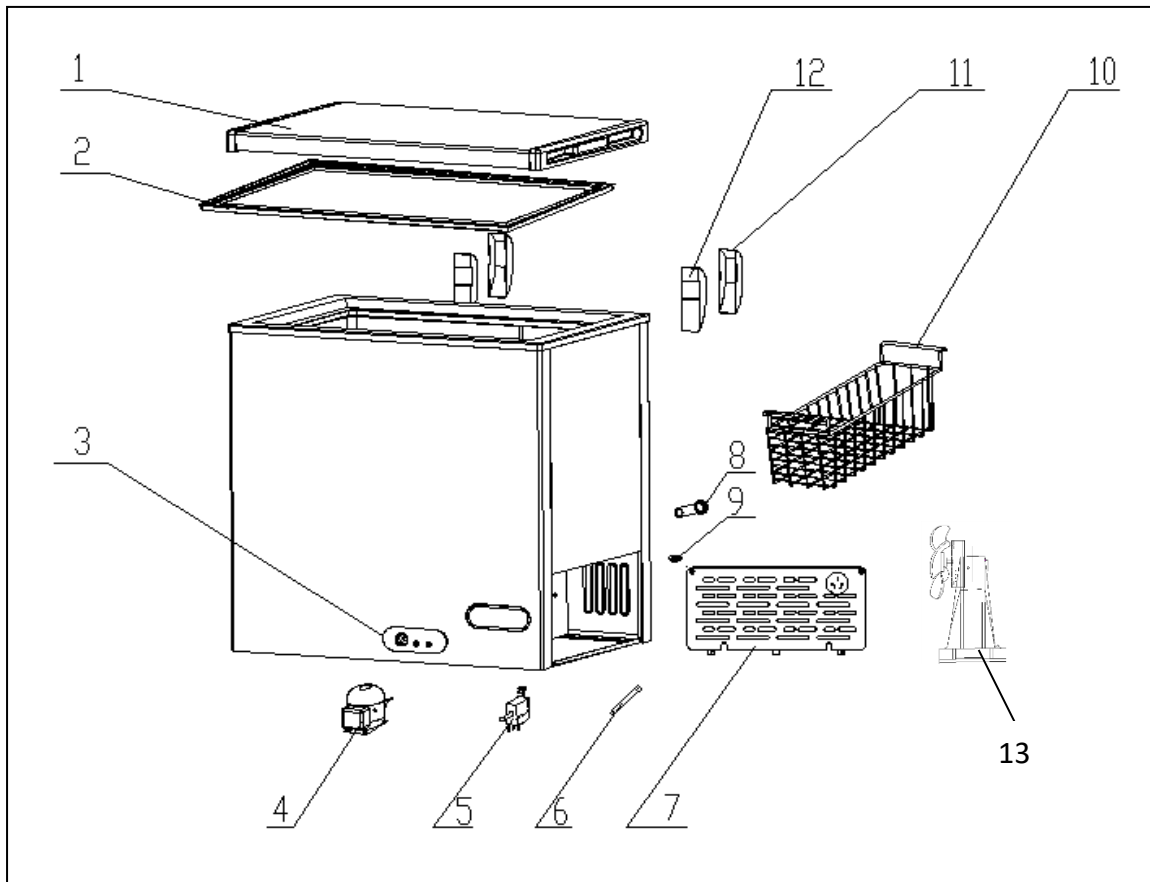

--Service part list

| No in explode view | Description | Service Part No |
|--------------------|------------------------------|------------------------|
| 1 | Door for BD-65 | BD65P001 |
| | Door for BD-105 | BD105P001 |
| | Door for BD-155 | BD155P001 |
| | Door for BD-205 | BD205P001 |
| | Door for BD-255 | BD255P001 |
| | Door for BD-350 | BD350P001 |
| | Door for BD-450 /450SS | BD450P001 /BD450SSP001 |
| | Door for BD-550 /550SS | BD550P001/BD550SSP001 |
| | Door for BD-650 /650SS | BD650P001/BD650SSP001 |
| 2 | Door Gasket for BD-65 | BD65P002 |
| | Door Gasket for BD-105 | BD105P002 |
| | Door Gasket for BD-155 | BD155P002 |
| | Door Gasket for BD-205 | BD205P002 |
| | Door Gasket for BD-255 | BD255P002 |
| | Door Gasket for BD-350 | BD350P002 |
| | Door Gasket for BD-450/450SS | BD450P002 |
| | Door Gasket for BD-550/550SS | BD550P002 |

| | | |
|----|---|------------------|
| | Door Gasket for BD-650/650SS | BD650P002 |
| 3 | Control Panel for BD/65/105/155/205/255/350/450/ 550/650/450SS/550SS/650SS | BD65P003 |
| 4 | Compressor for BD-65 | BD65P004 |
| | Compressor for BD-105 | BD105P003 |
| | Compressor for BD-155 | BD155P003 |
| | Compressor for BD-205 | BD205P003 |
| | Compressor for BD-255 | BD255P003 |
| | Compressor for BD-350 | BD350P003 |
| | Compressor for BD-450/450SS | BD450P003 |
| | Compressor for BD-550/550SS | BD550P003 |
| | Compressor for BD-650/650SS | BD650P003 |
| 5 | Thermostat for BD/65/105/155/205/255/350/450/ 550/650/450SS/550SS/650SS | BD65P005 |
| 6 | Filter for BD/65/105/155/205/255/350/450/ 550/650/450SS/550SS/650SS | BD65P006 |
| 7 | Compressor cover board for BD-65 | BD65P007 |
| | Compressor cover board for BD-105 | BD105P004 |
| | Compressor cover board for BD-155 | BD155P004 |
| | Compressor cover board for BD-205 | BD205P004 |
| | Compressor cover board for BD-255 | BD255P004 |
| | Compressor cover board for BD-350 | BD350P004 |
| | Compressor cover board for BD-450/450SS | BD450P004 |
| | Compressor cover board for BD-550/550SS | BD550P004 |
| | Compressor cover board for BD-650/650SS | BD650P004 |
| 8 | Outer Drain plug for BD/65/105/155/205/255/350/450/ 550/650/450SS/550SS/650SS | BD65P008 |
| 9 | Inner Drain plug for BD/65/105/155/205/255/350/ 450/550/650/450SS/550SS/650SS | BD65P009 |
| 10 | Basket for BD65/105/155/205/255 | BD65P010 |

| | | |
|----------------------------|---|-----------|
| | Basket for BD350 /450/550/650/450SS/550SS/650SS | BD350P005 |
| 11 | Hinge Cover for BD65/105/155/205/255 | BD65P011 |
| | Hinge Cover for BD350/450/550/650/450SS/550SS/ 650SS | BD350P006 |
| 12 | Door Hinge for BD65/105/155/205/255 | BD65P012 |
| | Door Hinge for BD350/450/550/650/450SS/550SS/ 650SS | BD350P007 |
| 13 | Fan MOTOR for BD65/105/155/205/255/350/ 450/550/650/450SS/550SS/650SS | BD65P013 |
| Not showed in explode view | Door Handle for BD255/350/450/550/650 | BD255P005 |
| Not showed in explode view | Caster for BD65/105/155/205/255/350/450/5 50/650/450SS/550SS/650SS | BD65P014 |

--Electric Connection Diagram

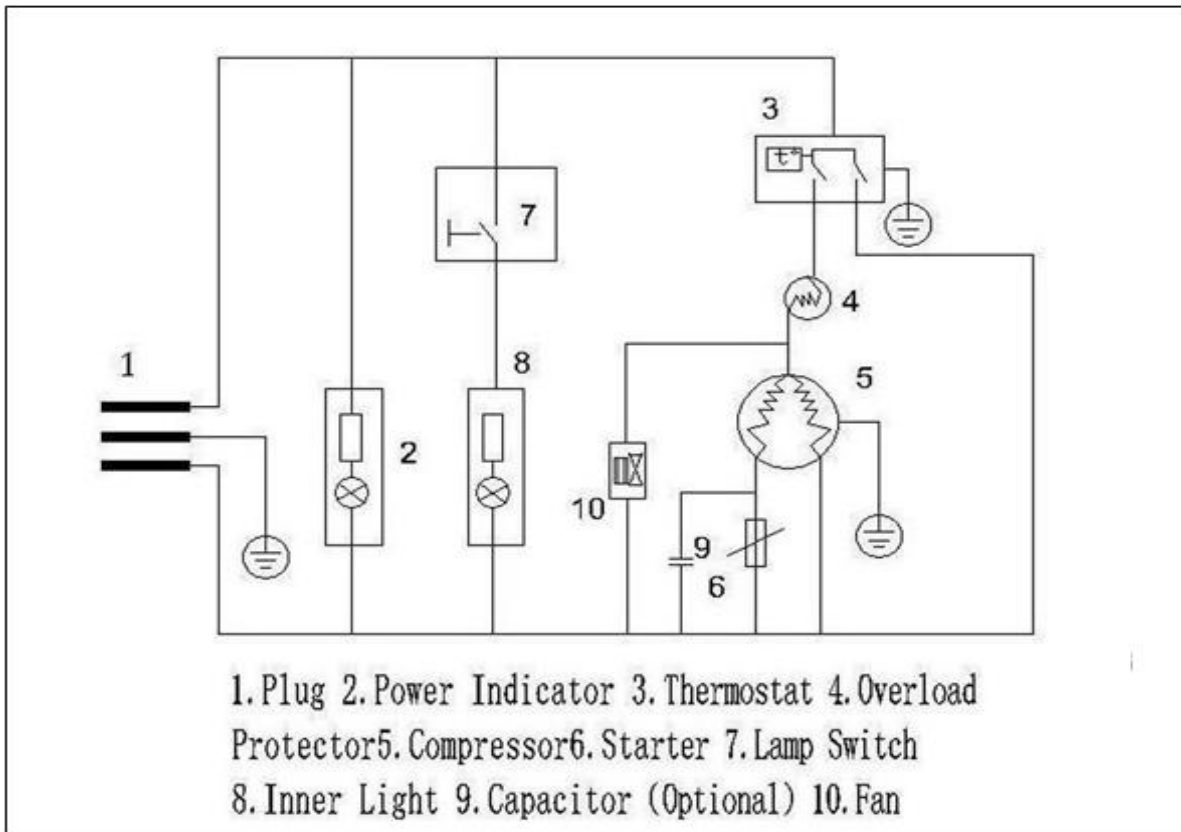

--TroubleShooting

| Problem or Concern | Possible Cause | Common Solution |
|--|---|---|
| The indicator is not on. The compressor does not start. | The plug isn't connected to the socket really. | Replug it. |
| | no power | Connect the socket with power. |
| The indicator is on ,but the compressor doesn't work and buzzes only | The power voltage is <98V. | Connect a voltage-regulator (with more than 1000w capacity). |
| The compressor stops a minute after start, and restart after a few minutes, and so repeatedly. | The power voltage is >132V. | |
| The compressor works normally, but the temperature in the cabinet goes down too slowly. | The door is opened too frequently. | Reduce open times. |
| | The food in the cabinet is too much, and placed improperly. | Place foods properly keep place between them for ventilation of cold air. |
| | The frost layer is too thick. | Take out foods and defrost. |
| | The surface of the condenser is too dirty. | Stop and clean the condenser. |
| | The door seals badly. | Adjust the door seal. |
| The noise is too loud | The freezer is placed unstably. | Place it stably. |
| | The fixing of the freezer is loose. | Tighten the fixing. |
| | there's contact between pipes. | Separate them. |

The following are not faults:

- When the freezer is working or after is stops for a while, the refrigerant in the pipes is cycling and gives out running water " sounds.
- The surface temperature of the compressor may be up 150°F when it is working.
- The back side of step freezer gives out heat.
- In rainy season, the outer surface of the cabinet may have dew, which makes no defects on normal use. Just dry it with a piece of cloth.